

# STC Explosion Proof Solenoid Coils for Use in Hazardous Environments



200C-E Coil





200C-ATEX Coil



2W200C-ATEX Coil

## 2P050 Series Solenoid Valve Specifications

Valve Model	200C-E	200C-ATEX	2W200C-ATEX
Compatible STC Valves	2P025, 2V025, 3P010, 2S012-020, 3S012, 2V130-250, 3V110-410, 4V110-410		2P050, 2S025-050, 3S020-035, 2S160-250, 2W160-250, 2R130-500, 2RS130-500, 2RSO130-500, 2RO130-500
Ratings & Certifications	 CSA Class 2258 02 FM Class 3600, 3611, 3615, 3810 RoHS Compliant	 PTB 00 ATEX 2001 X RoHS Compliant	 PTB 03 ATEX 2086 X, IECEx PTB 05.0005X RoHS Compliant
*Protection by Encapsulation	AEx m II T4 Div 1	Ex II 2 G Ex mb IIC T5, T4, Gb Ex II 2 D Ex mb tb IIIC T95°C, T130°C Db	Ex II 2 G Ex mb II T6, T5, T4 Gb Ex II 2 D Ex tb IIIC T80°C, T95°C, T130°C Db
Coil Specs	F Class, 100% Continuous Duty, IP65, ± 10% Specified Voltage		
Voltage Options	DC: 12V, 24V AC: 120V (60Hz), 240V (60Hz)	DC: 12V, 24V AC: 24V (50/60Hz), 110V (50/60Hz), 220/240V (50/60Hz)	DC: 24V AC: 24VAC, 110V (50/60Hz), 230V (50/60Hz)
Coil Power	DC: 4.5—4.6W AC: 6.8VA	DC: 4.5W (12V), 5W (24V) AC: 4.6VA (24V), 4.5VA (110V), 4.2-4.4VA (220/240V)	DC: 5.2W AC: 7.2VA (24V), 9.1VA (110V), 8.5VA (230V)
Cable & Connection	1/2" NPT with 24" 3-Strand Wires	3m 3-Wired Cable & Sleeve, DIN 43650B	3m 3-Wired Cable & Sleeve, DIN 43650A
Ambient Temperature	-4 to 122°F (-20 to 50°C)		

\*See following pages for addition specification information regarding CSA, FM, and ATEX certifications

# Additional Coil Specifications // 200C-E Coil

## Applicable Standards:



**CSA** Class I, Zone 1, Ex m II T4  
Class I, Div. 1 & Div. 2, Groups A,B,C, D  
Class II, Groups E, F, G; Class III; T4

**FM** Class I, Zone 1, AEx m II T4  
Class I, Div. 1 & Div. 2, Groups A, B, C, D  
Class II, Groups E, F, G; Class III; T4

Compliance Statement # 202633

Compliance Statement # 3006713

This solenoid coil is an encapsulated electrical device as per Group II, designed for applications in hazardous locations according to Zone 1 and Division 1 & 2 for temperature Class T4.

## Applicable Specifications:

CAN/CSA-E79-0-95 / IEC 60079-0 /	Electrical apparatus for explosive atmospheres, Part 0: General Requirements
ANSI/ISA-S12.00.01-1999	
CAN/CSA-E79-18-95 / IEC 60079-18:1992 / ANSI/ISA-S12.23.01-1998	Electrical apparatus for explosive atmospheres, Part 18: Encapsulation “m” / Electrical apparatus for use in Class I, Zone 1 Hazardous (classified) locations: Type of protection Encapsulation “m”
CSA-C22.2 No.0-M91	General Requirements—Canadian Electrical Code, Part II
No. 142-M1987	Process Control Equipment
No. 0.4-M1982	Bonding & Grounding of Electrical Equipment (Protective Grounding)
No. 0.5-1982	Threaded Conduit Entries
No. 25-1966	Enclosures for Use in Class II, Groups E, F, and G; Hazardous Locations
TIL (May 31, 1990)	Protection by Encapsulation of Electrical Apparatus for Use in Hazardous Locations

## Applicable to Divisions when combined with:

Class Number 3600:1998	Electrical equipment for use in hazardous (classified) locations, General Requirements, Clauses 5.2 & 5.3
Class Number 3615:1989	Explosion Proof electrical equipment, Clauses 4.3 & 4.7
ANSI/ISA S82.01 & S82.03	Electrical & electronic test, measurement, and process control equipment + NF
EC Directive 2011/65/EU	Restriction on the use of certain hazardous substances in electrical equipment

## Encapsulation Protection:

**Ex m** Class I, Zone 1

**AEx m**



# Additional Coil Specifications // 200C-ATEX Coil

## Applicable Standards:



## ATEX



II 2 G Ex mb IIC T4 Gb

II 2 D Ex mb tb IIIC

Compliance Statement # PTB 00 ATEX 2001 X

This solenoid coil is an encapsulated safe electrical apparatus of Group II, designed for application in atmospheres according to Category 2G & 2D, the EPL is Gb & Db, Temperature Class 4.

This device, which is provided with the CE symbol, meets the following standards & directives:

EN 60070-0:2009	Explosive Atmospheres—Part 0: Equipment—General Requirements
EN 60079-18:2009	Explosive Atmospheres—Part 18: Equipment Protection by Encapsulation “m”
EN 60079-31:2009	Explosive Atmospheres—Part 31: Equipment Dust Ignition Protection by Enclosure “t”
EN 60529:2000	Degrees of Protection Provided by Enclosures (IP Code)
DIN VDE 0580:2000	Electromagnetic Devices & Components—General Specifications
Directive 94/9/EC	Equipment & Protective Systems for Use in Potentially Explosive Atmospheres
EC Directive 2011/65/EU	Restriction on the use of certain hazardous substances in electrical equipment

## Encapsulation Protection:

<b>Ex mb</b>	Class I, Zone 1 EPL Gb Category 2G
<b>Ex tb</b>	Dust Zone 21 & 22 Category 2D

# Additional Coil Specifications // 2W200C-ATEX Coil

## Applicable Standards:



### ATEX



II 2 G Ex mb IIC T4 Gb  
II 2 D Ex mb tb IIIC

### IEC

Ex mb IIC T4, T5 Gb  
Ex mb tb IIIC T130°C, T95°C

Compliance Statement # PTB 03 ATEX 2086 X

Compliance Statement # IECEx PTB 05.0005X

This solenoid coil is an encapsulated safe electrical apparatus of Group II, designed for application in atmospheres according to Category 2G & 2D, the EPL is Gb & Db, Temperature Classes 4 & 5.

This device, which is provided with the CE symbol, meets the following standards & directives:

EN 60070-0:2009	Explosive Atmospheres—Part 0: Equipment—General Requirements
EN 60079-18:2009	Explosive Atmospheres—Part 18: Equipment Protection by Encapsulation “m”
EN 60079-31:2009	Explosive Atmospheres—Part 31: Equipment Dust Ignition Protection by Enclosure “t”
EN 60529:2000	Degrees of Protection Provided by Enclosures (IP Code)
DIN VDE 0580:2000	Electromagnetic Devices & Components—General Specifications
Directive 94/9/EC	Equipment & Protective Systems for Use in Potentially Explosive Atmospheres
EC Directive 2011/65/EU	Restriction on the use of certain hazardous substances in electrical equipment

## Encapsulation Protection:

<b>Ex mb</b>	Class I, Zone 1 EPL Gb Category 2G
<b>Ex tb</b>	Dust Zone 21 & 22 Category 2D

# Explosion Proof Solenoid Dimensions

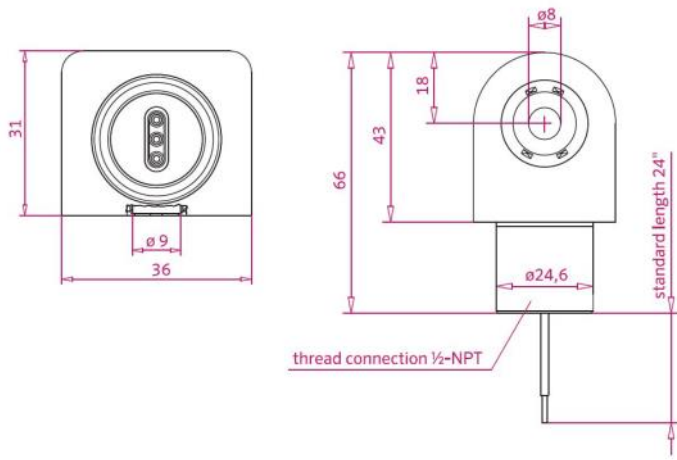

**200C-E**

22 mm

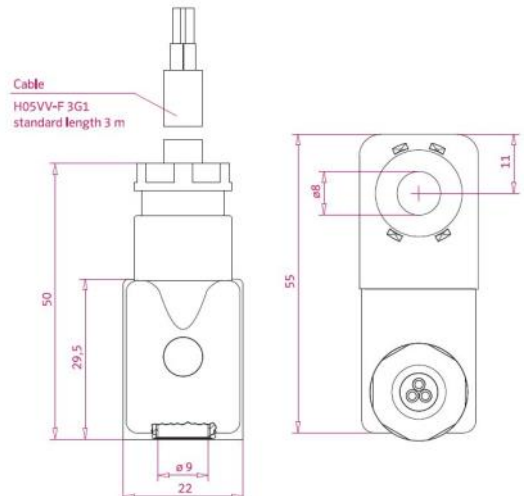

**200C-ATEX**

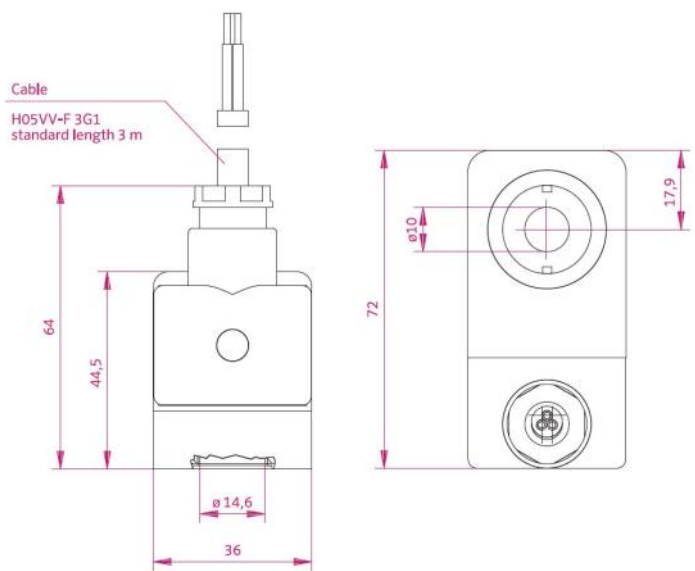

**2W200C-ATEX**



# Hazardous Area Ratings Overview

## HAZARDOUS AREA CLASSIFICATIONS

When electrical equipment is used in an atmosphere where flammable gases or vapors, flammable liquids, ignitable fibers, or combustible dusts may be present, there exists a possibility of fire or explosion. These areas are often referred to as a Hazardous (or Classified) Area. There are two systems currently used to classify these Hazardous Areas:

1. The Class/Division System
2. The Zone System

The Class/Division system is primarily used in the United States & Canada, while the rest of the world generally uses the Zone system.

## THE CLASS/DIVISION SYSTEM

Hazardous Areas per the Class/Division system are categorized according to Class, Division, and Group.

1. *Class*. The Class of a Hazardous Area defines the general properties of the material in the surrounding atmosphere.
  - a. Class I. Locations in which flammable gases or vapors may or may not be in sufficient quantities to produce explosive or ignitable mixtures.
  - b. Class II. Locations in which combustible dusts (either in suspension, intermittently, or periodically) may or may not be in sufficient quantities to produce explosive or ignitable mixtures.
  - c. Class III. Locations in which ignitable fibers may or may not be in sufficient quantities to produce explosive or ignitable mixtures.
2. *Division*. The Division of a Hazardous Area defines the probability of the hazardous material being able to produce an explosive or ignitable mixture based on its presence.
  - a. Division 1 indicates that the hazardous material has a high probability of producing an explosive or ignitable mixture due to it being present continuously, intermittently, or periodically or from the equipment itself under normal operating conditions.
  - b. Division 2 indicates that the hazardous material has a low probability of producing an explosive or ignitable mixture and is present only during abnormal conditions for a short period of time.
3. *Group*. The Group of a Hazardous Area defines the type of hazardous material in the surrounding atmosphere. Groups A, B, C, and D are for gases (Class I only). Groups E, F, and G are for dusts & flyings (Class II or III).
  - a. Group A. Atmospheres containing acetylene.
  - b. Group B. Atmospheres containing a flammable gas, flammable liquid-produced vapor, or combustible liquid-produced vapor where:  $MESG \leq 0.45\text{mm}$  or  $MIC \text{ Ratio} < 0.40$ .
  - c. Group C. Atmospheres containing a flammable gas, flammable liquid-produced vapor, or combustible liquid-produced vapor where:  $0.45\text{mm} < MESG \leq 0.75\text{mm}$  or  $0.40 < MIC \text{ Ratio} \leq 0.80$ . Typical gases include ethyl ether, ethylene, acetaldehyde, and cyclopropane.
  - d. Group D. Atmospheres containing a flammable gas, flammable liquid-produced vapor, or combustible liquid-produced vapor where:  $MESG > 0.75\text{mm}$  or  $MIC \text{ Ratio} > 0.80$ . Typical gases include acetone, ammonia, benzene, butane, ethanol, gasoline, methane, natural gas, naphtha, and propane.
  - e. Group E. Atmospheres containing combustible metal dusts such as aluminum, magnesium, and their commercial alloys.
  - f. Group F. Atmospheres containing combustible carbonaceous dusts with 8% or more trapped volatiles such as carbon black, coal, or coke dust.
  - g. Group G. Atmospheres containing combustible dusts not included in Group E or Group F. Typical dusts include flour, starch, grain, wood, plastic, and chemicals.

# Hazardous Area Ratings Overview (continued)

## ZONE SYSTEM

Hazardous Areas per the Zone system are categorized according to Zone, which can be gas or dust.

*Zone.* The Zone defines the probability of hazardous material, gas or dust, being present in sufficient quantities to produce explosive or ignitable mixtures.

### 1. Gas

- a. Zone 0. Ignitable concentrations of flammable gases or vapors which are present continuously or for long periods of time.
- b. Zone 1. Ignitable concentrations of flammable gases or vapors which are likely to occur under normal operating conditions.
- c. Zone 2. Ignitable concentrations of flammable gases or vapors which are not likely to occur under normal operating conditions and do so only for a short period of time.

### 2. Dust

- a. Zone 20. An area where combustible dusts or ignitable fibers & flyings are present continuously or for long periods of time.
- b. Zone 21. An area where combustible dusts or ignitable fibers & flyings are likely to occur under normal operating conditions.
- c. Zone 22. An area where combustible dusts or ignitable fibers & flyings are not likely to occur under normal operating conditions and do so only for a short period of time.

*Group.* Electrical equipment is divided into three groups.

1. Group I. Equipment intended for use in mines susceptible to firedamp (flammable mixture of gases naturally occurring in a mine).

2. Group II. Equipment intended for use in places with an explosive gas atmosphere other than mines susceptible to firedamp. Group II equipment is subdivided into three subgroups:

- a. Group IIA. Atmospheres containing propane, or gases & vapors of equivalent hazard.
- b. Group IIB. Atmospheres containing ethylene, or gases & vapors of equivalent hazard.
- c. Group IIC. Atmospheres containing acetylene or hydrogen, or gases & vapors of equivalent hazard.

3. Group III. Equipment intended for use in places with an explosive dust atmosphere, Group III equipment is subdivided into three subgroups:

- a. Group IIIA. Atmospheres containing combustible flyings.
- b. Group IIIB. Atmospheres containing non-conductive dust.
- c. Group IIIC. Atmospheres containing conductive dust.

# Approvals Overview

## Approval Types

In general, most countries require that products intended for installation in a hazardous location be approved by a recognized authority or approval agency which that country has established by various laws, regulations, or codes. The table below includes an overview of approvals & agencies, with a column indicating which STC Explosion Proof Coils meet each approval.

Approval	200C-E	200C-ATEX	2W200C-ATEX	Approvals Generally Accepted
FM	X			North America
CSA	X			North America
ATEX		X	X	European Union
IECEX			X	International
CE		X	X	European Union

Area Classification			
IEC / EU	Zone 0	Zone 1	Zone 2
US (NEC 505)	Zone 0	Zone 1	Zone 2
US (NEC 506)	Division 1		Division 2
CA (CEC Sec. 18)	Zone 0	Zone 1	Zone 2
CA (CEC Annex J)	Division 1		Division 2

## Equipment Protection Level (EPL)/Category

Definition	IEC		EU (ATEX)		Typical Zone of Application
	EPL	Group	Category	Group	
Mines, "very high" level of protection	Ma	I	M1	I	N/A
Mines, "high" level of protection	Mb		M2		
Gas Atmospheres, "very high" level of protection	Ga	II	1G	II	0
Gas Atmospheres, "high" level of protection	Gb		2G		1
Gas Atmospheres, "enhanced" level of protection	Gc		3G		2



# Electrical Connections

## To Connect a DIN Coil:

- Remove the Philips screw from the plastic housing & unplug from the DIN coil.
- Use the removed screw to push the terminal block out of the plastic DIN housing.
- Note the “1”, “2”, and ground “ $\perp$ ” symbols.
  - For DC DIN Coils, connect “1” to your positive lead & “2” to your negative lead.
  - For AC DIN Coils, connect “1” to your HOT lead, “2” to your NEUTRAL lead, and “ $\perp$ ” to your ground lead, if required.

## To Connect a Grommet Coil:

- For DC Coils, connect the red wire to your positive lead & the black wire to your negative lead.
- For AC Coils, connect the black wire to your HOT lead & the white wire to your NEUTRAL lead.
- For Coils provided with Molded Cables, the color of the wire indicates the type of lead:
  - GREEN = Ground Wire
  - BLUE = Positive or HOT Wire
  - BROWN = Negative or Neutral Wire

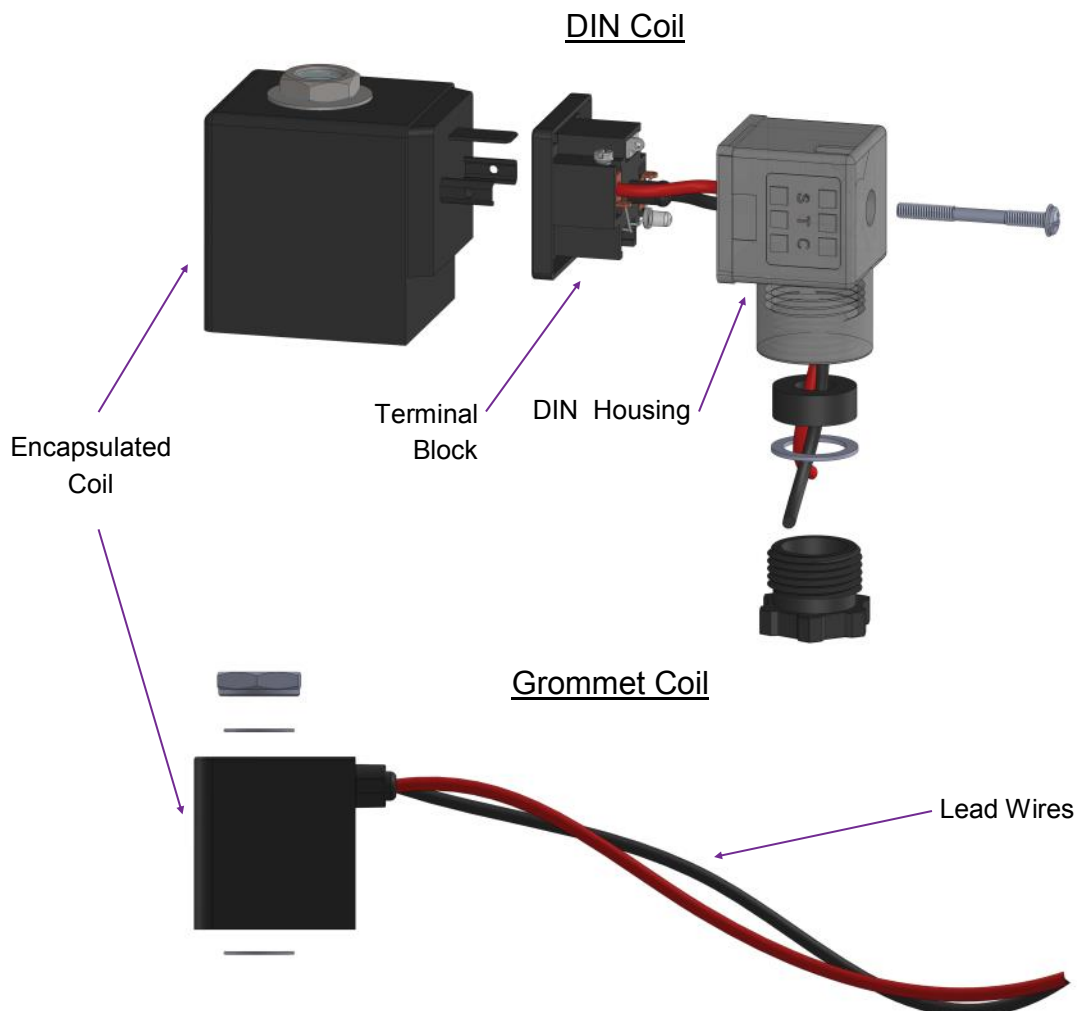

# Terms & Conditions

By purchasing from SIZTO TECH CORPORATION (STC), you agree to these TERMS AND CONDITIONS. No other terms shall apply except as agreed in writing & signed by STC. We reserve the right to correct typographic errors and reject orders.

## SHIPMENTS:

All shipments are F.O.B. 892 Commercial Street, Palo Alto, CA 94303, USA. Most orders are shipped via UPS Standard Ground unless instructions accompany order. Outside the UPS zones, shipment will be made Best Way. The responsibility for goods delay, lost or damaged in transit rests with the carrier and purchaser. Purchaser may purchase shipping insurance to cover lost or damaged products caused by shipping.

## RETURN OF MERCHANDISE:

No merchandise is accepted for return 30 days after delivery date. No credit allowed on merchandise shipped as ordered and returned without obtaining an authorization number IN ADVANCE. A 20% restocking charge applies to all returns, and transportation charges must be fully prepaid. We will pay **ground** transportation charges on re-sent or returned merchandise due to STC's error.

**Shortages & Mis-Shipments:** Any shortages or mis-shipments must be reported within 15 days.

## CANCELLATION POLICY:

Blanket orders can be canceled 90 days before scheduled ship date. There will be a 10% charge if a blanket order is canceled within 90 days of scheduled ship date, and a 20% charge if canceled within 60 days. Regular orders for non-custom parts can be canceled any time before the order is shipped. For custom parts, a 30% down payment is required either at the time of order or 90 days prior to scheduled ship date, whichever comes later.

## Remittances should be sent to:

Sizto Tech Corporation, 892 Commercial Street, Palo Alto, CA 94303, USA

Credit Card Payments: Visa, MasterCard, Discover, or American Express accepted

**International Customers:** Advance Payment Required via Bank Wire, Cashier's Check or Approved Credit Card.

**Credit Application:** To establish a net 30 day account, please mail or fax three trade references with complete mailing addresses and account numbers, or request an STC Credit Application.

## LIMITED WARRANTY – IMPORTANT NOTICE TO PURCHASER:

Sizto Tech Corporation (STC) only warrants this product to be free from defects in materials and workmanship at the time of shipment. This limited warranty expires one year after delivery to the end-user. STC's entire obligation to the Purchaser for breach of this limited warranty shall be limited to replacement of the defective product or refund of the original purchase price of this product, at STC's option. Purchaser has thirty (30) days to return the goods after STC has agreed to accept the return. All freight charges on returned material shall be paid by the Purchaser. STC's limited warranty shall not apply, however, to the product that have been subjected to misuse, alteration, accident or negligence during handling or storage.

## DISCLAIMER OF IMPLIED WARRANTIES:

All implied warranties, which may arise by implication of law or application of course of dealing or usage of trade, including, but not limited to, implied warranties of merchantability or fitness for a particular purpose are expressly excluded. There are no warranties, which extend beyond the description of the faced hereof. The end user is solely responsible for the suitability and fitness of this product selected for a particular application.

## OBLIGATIONS

You warrant, represent and agree: (1) to comply with all laws; (2) that our sale and shipment of the product will not, by export thereof, your legal status or otherwise, cause us to violate any law; and (3) to indemnify us against any losses from a failure by you or a third party to comply with law or these terms and conditions, or from use of the product.

## SAFETY

**WARNING:** Improper Selection or Failure to follow Usage Instructions of the products described on the Sizto Tech Corporation (STC) Internet Site and its related publications can cause Death, Personal Injury, and Property Damage. All system set-ups require the supervision of a qualified individual who is familiar with installation, inspection and testing through training or experience.

## IMPORTANT NOTICE:

All prices are subject to change without notice. We continuously improve the products, and we reserve the right to change specifications without incurring any obligation to incorporate new factors in equipment previously sold.

Information contained herein may be changed without prior notification.

## Sizto Tech Corporation

892 Commercial Street  
Palo Alto, CA 94043 USA  
Tel: 650-856-8833 | Fax: 650-856-8811  
Email: Sales@StcValve.com | www.StcValve.com



[www.StcValve.com](http://www.StcValve.com)